

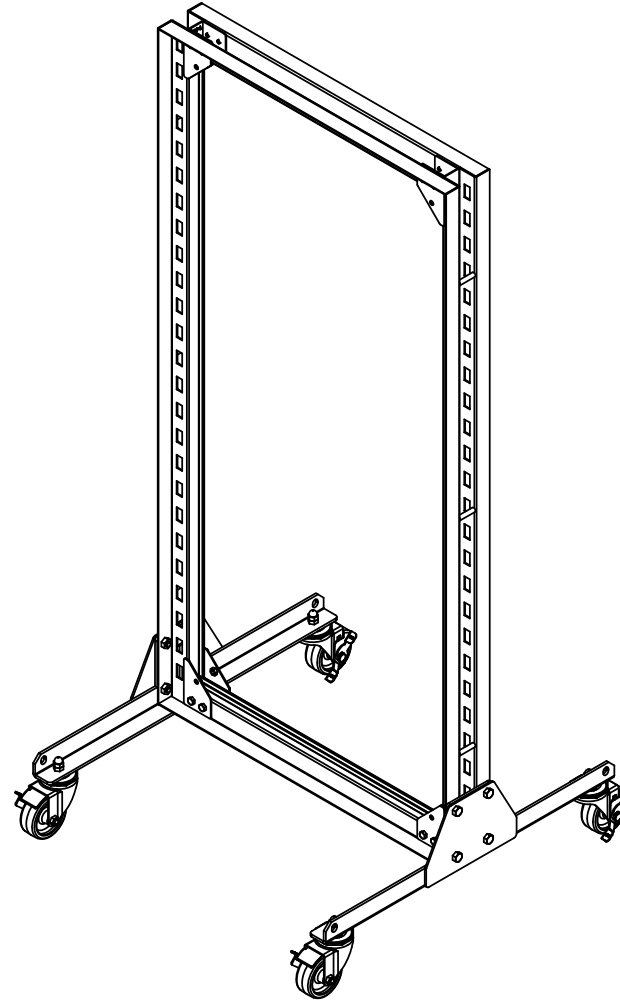

ASTORIA
ASSEMBLY INSTRUCTIONS



PART LIST:

TOP-L = LEFT
UPRIGHT

TOP-R = RIGHT
UPRIGHT

BOTTOM-BOTTOM =
BOTTOM RAIL. THIS
SIDE IS FACING DOWN

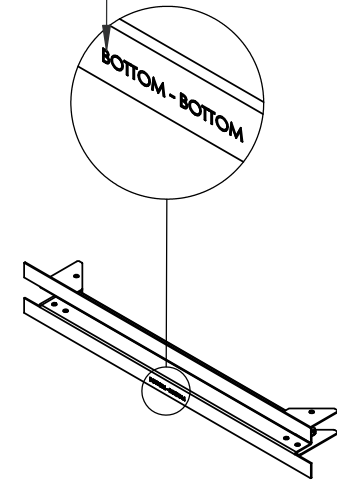
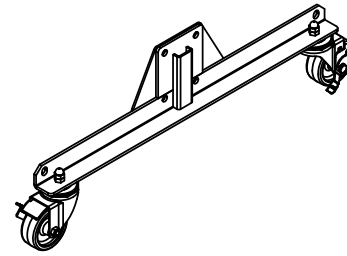
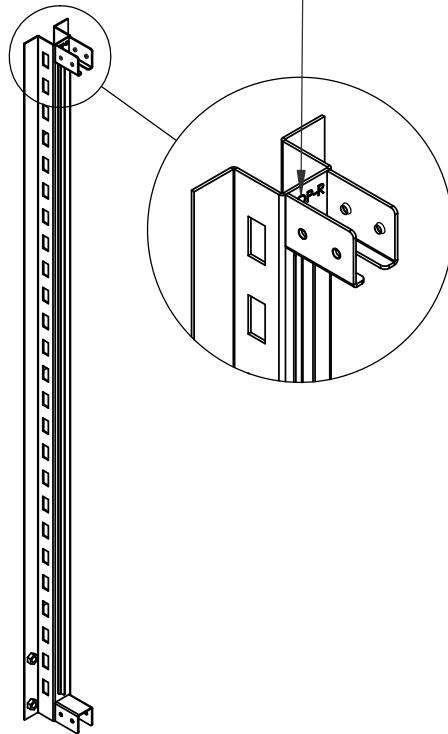
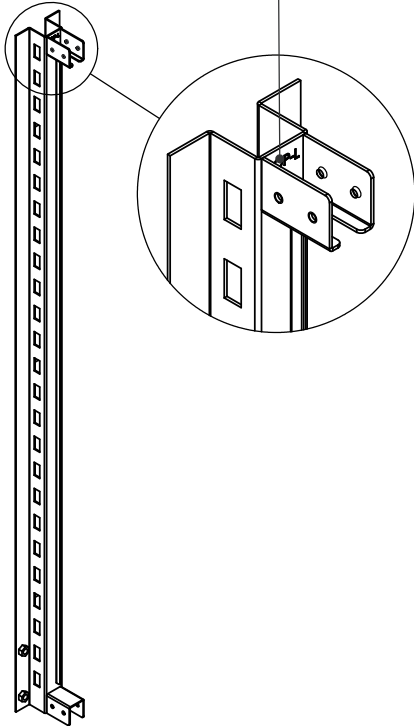

1X. LEFT UPRIGHT

1X. RIGHT UPRIGHT

2X. LEG

1X. BOTTOM RAIL

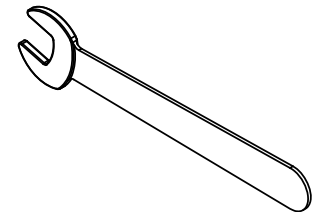
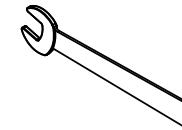
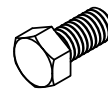
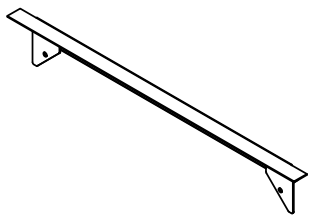

2X. TOP RAIL

16X. HEX BOLT 1/4"-20 X 0.4375"

8X. HEX BOLT 3/8"-16 X 0.75"

1X. OPEN END WRENCH
FOR 1/4"-20

1X. OPEN END WRENCH
FOR 3/8"-16

STEP 1:

ORIENT UPRIGHTS USING THE GUIDE ON PREVIOUS PAGE.

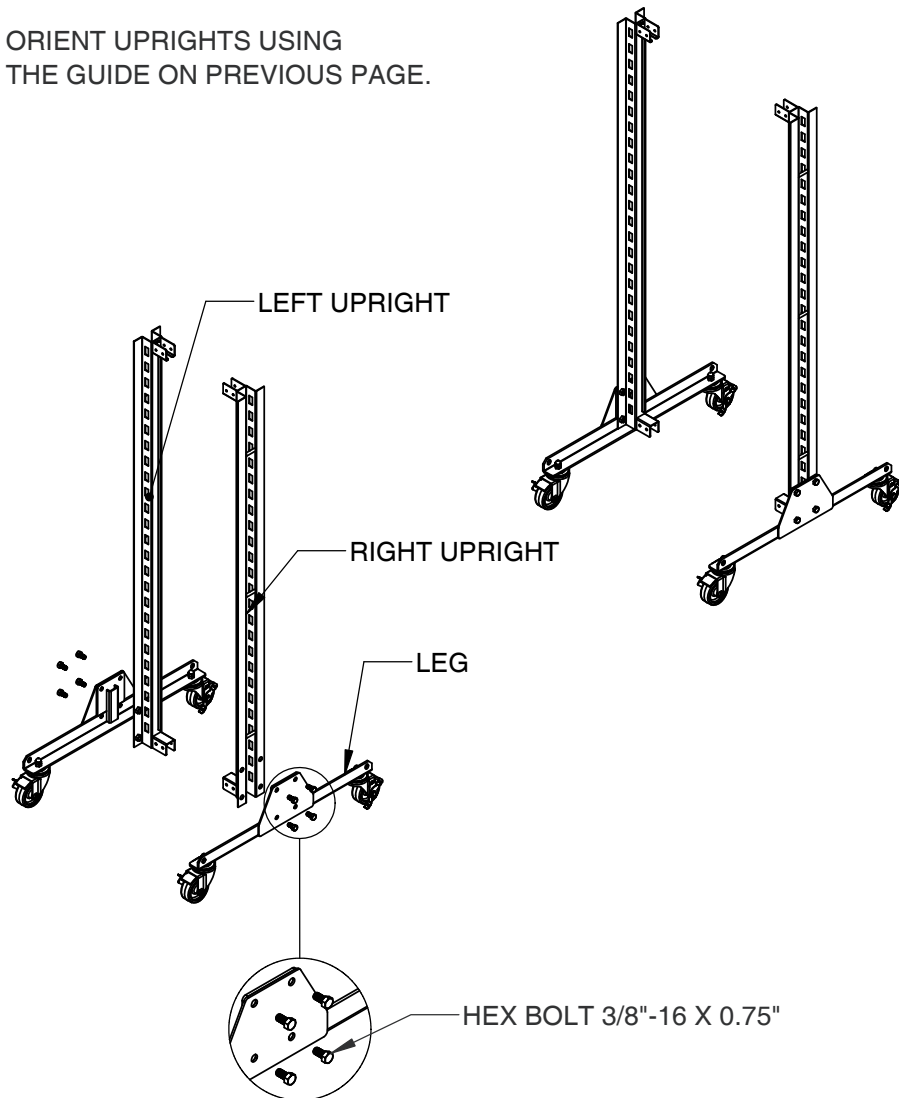

STEP 2:

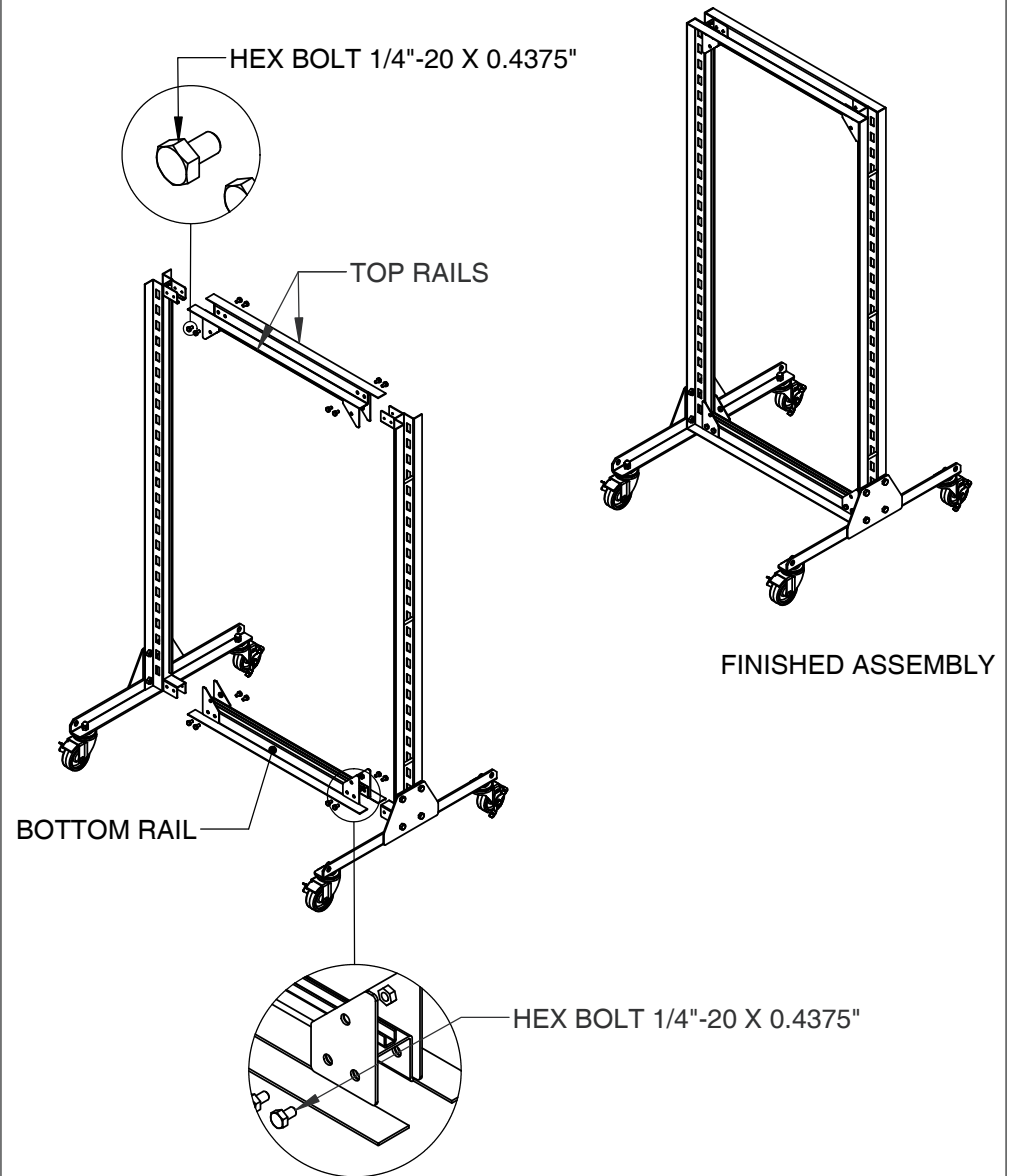

STEP 3: W/ OPTIONAL CROSS BRACES

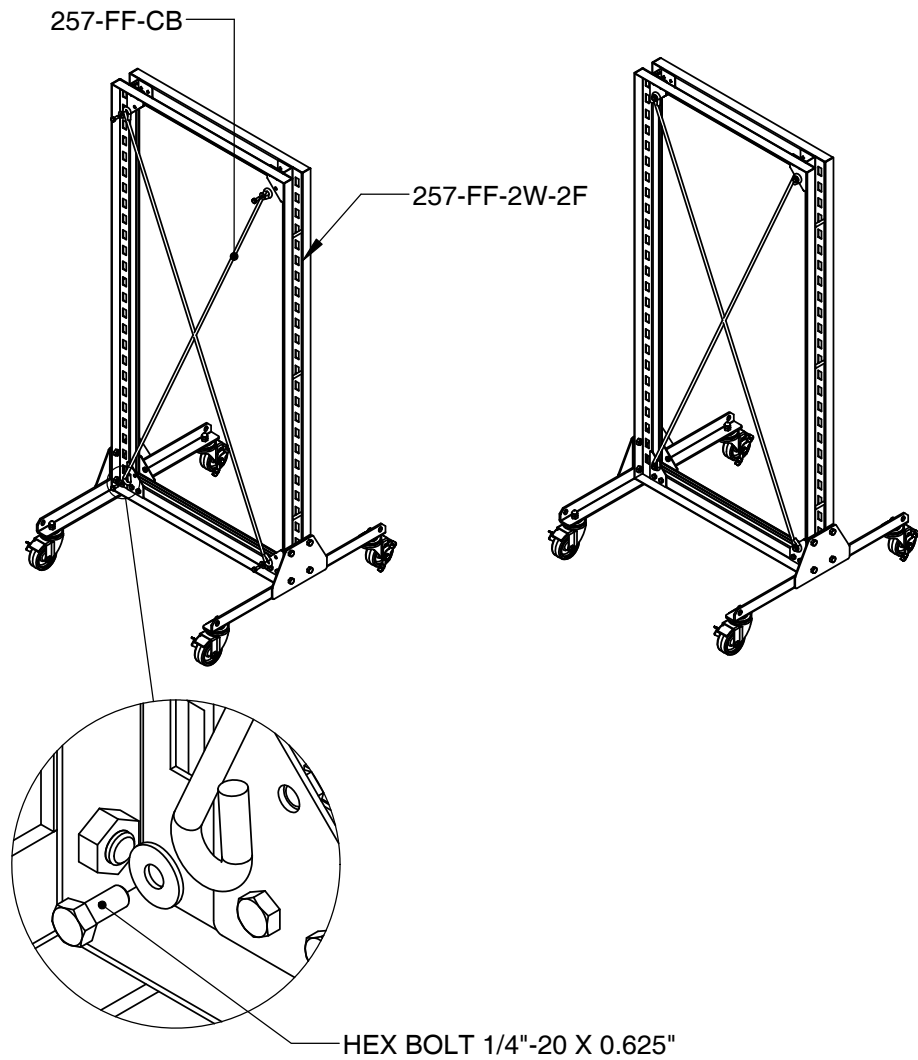

STEP 3: W/ OPTIONAL BACK PANELS

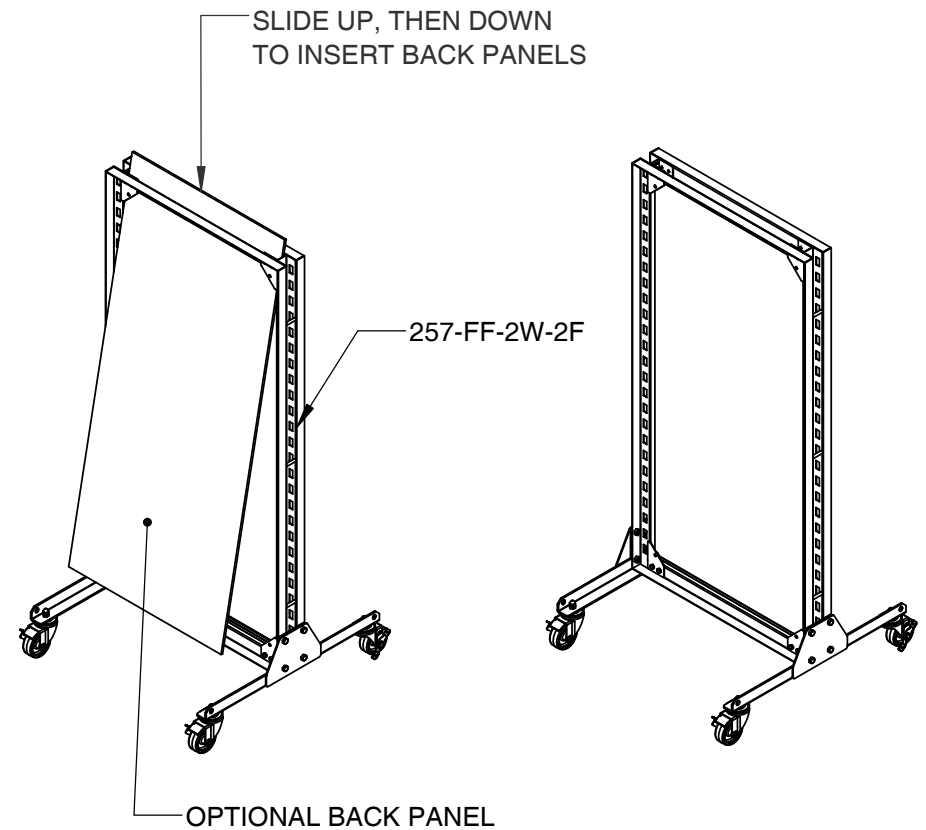



ASTORIA
ASSEMBLY INSTRUCTIONS

FLOOR END CAP :: 257-FF-EC

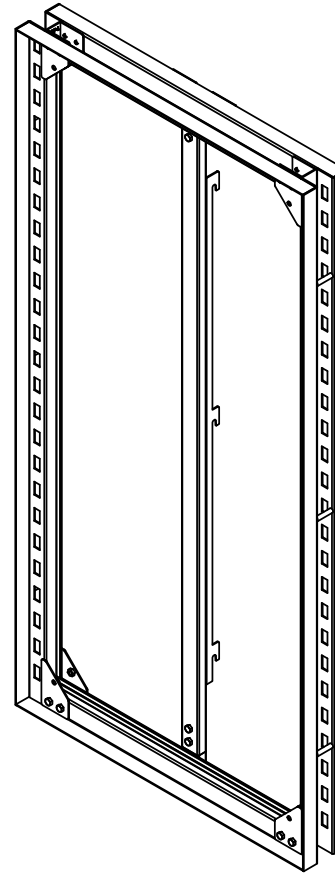

PART LIST:

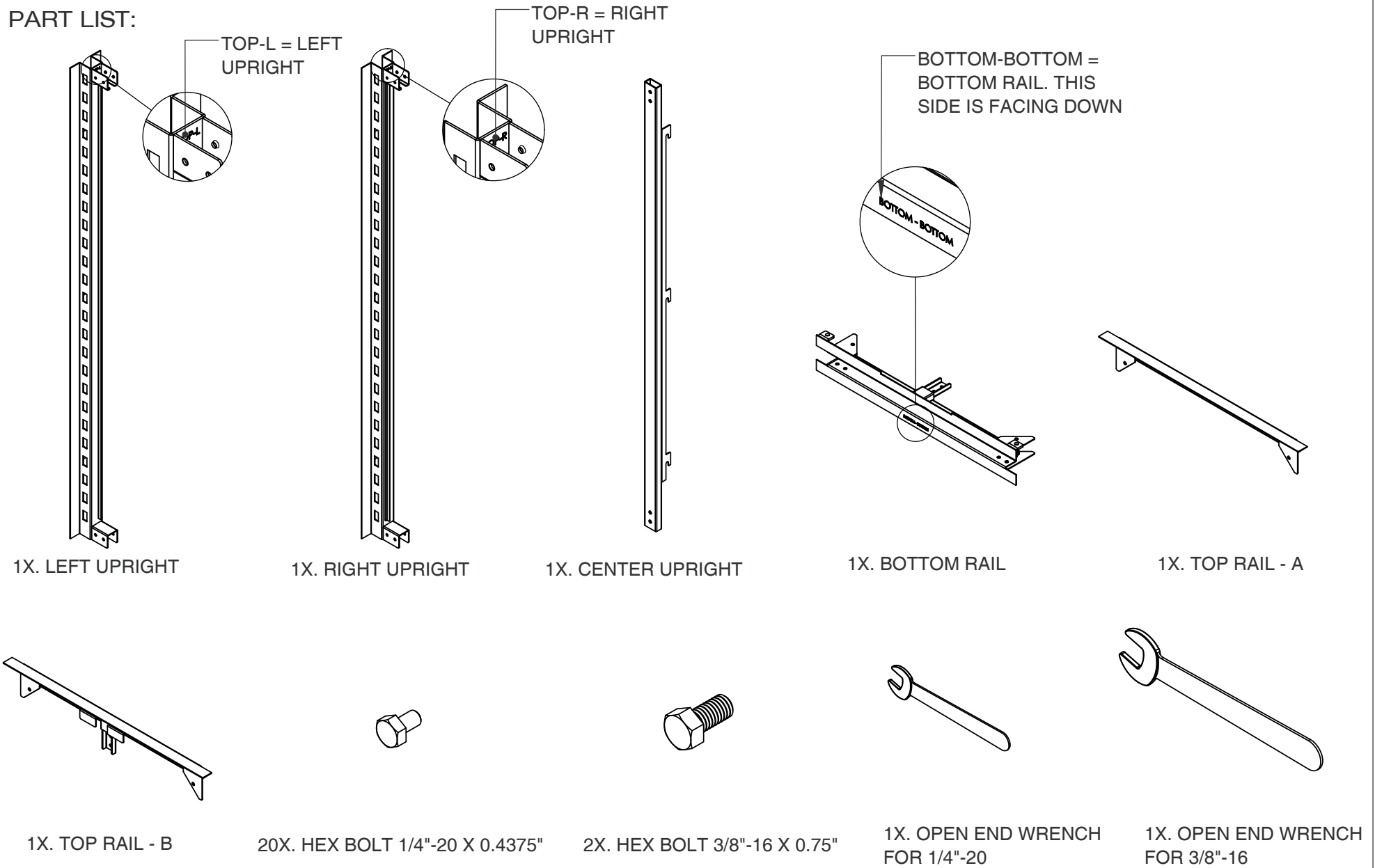

STEP 1:

ORIENT UPRIGHTS ACCORDING TO GUIDE ON PREVIOUS PAGE.

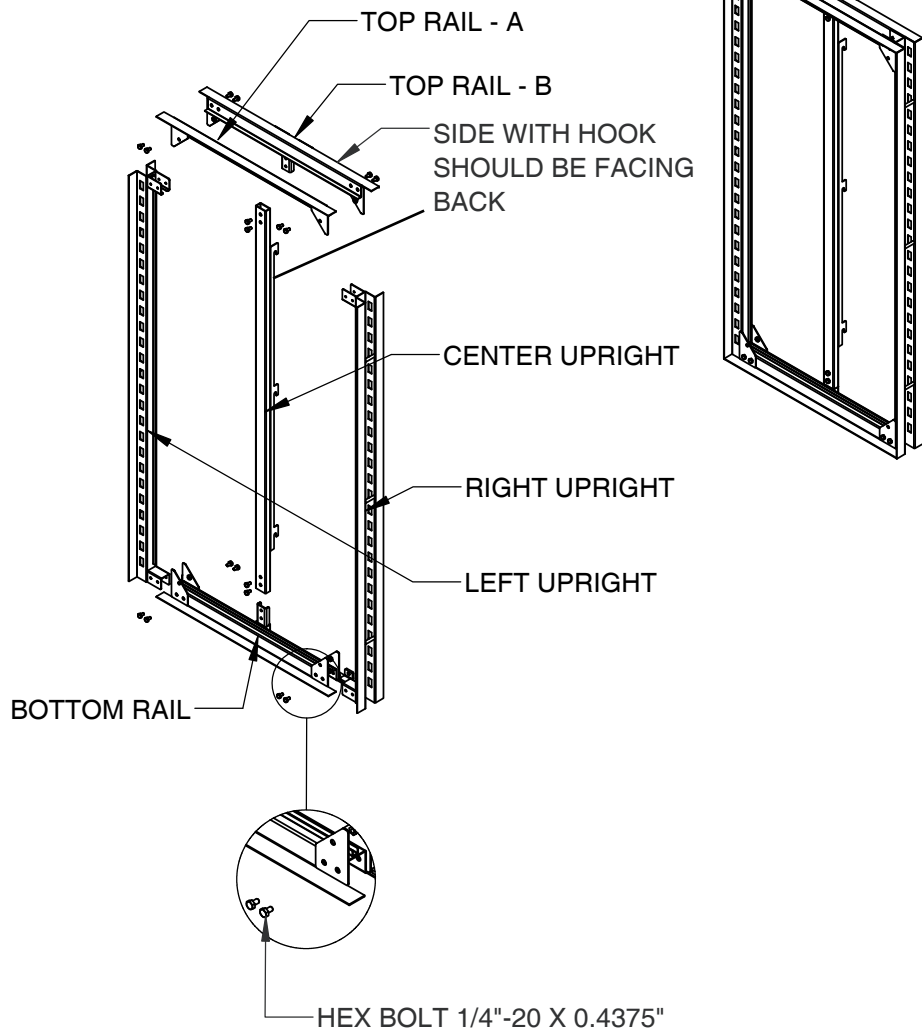

STEP 2:

