

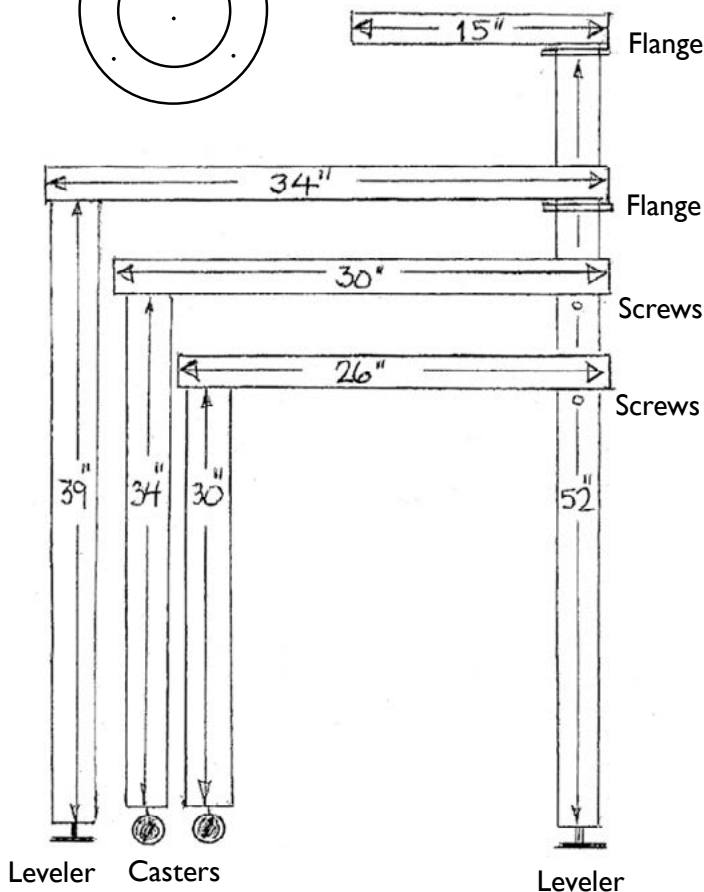

Top side of Flange

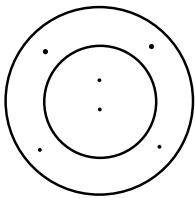

Step 1 - Screw casters onto 30" and 34" legs and levelers onto the 39" and 52" legs.

Step 2 - Screw table legs to the table tops as shown in drawing. Join 34" table top with 39" legs, 30" table top with 34" legs and 26" table top with the 30" legs. Secure with Phillips head screw driver.

Step 3 - Slide 34" pie table over 52" leg to rest on flange. Do not screw table to the leg, its made to pivot.

Step 4 - Start from the bottom of the 52" leg and slide 30" pie table upwards. Secure both screws with Allen wrench.

Step 5 - Repeat step 4 with 26" pie table.

Step 6 - Screw flange to the top of 52" leg and then secure to 15" pie table.