

BURNSIDE

ASSEMBLY INSTRUCTIONS

2 WAY // 292-2WAY

Made of 1¼" square tubing in
Metallic Silver finish

4" steel/rubber casters (2 locking)

Use with optional 47¾" x 20"
Perforated Metal or Frosted
Acrylic Back Panels available
and sold separately

25¼" W x 57.15" H x 25¼" D

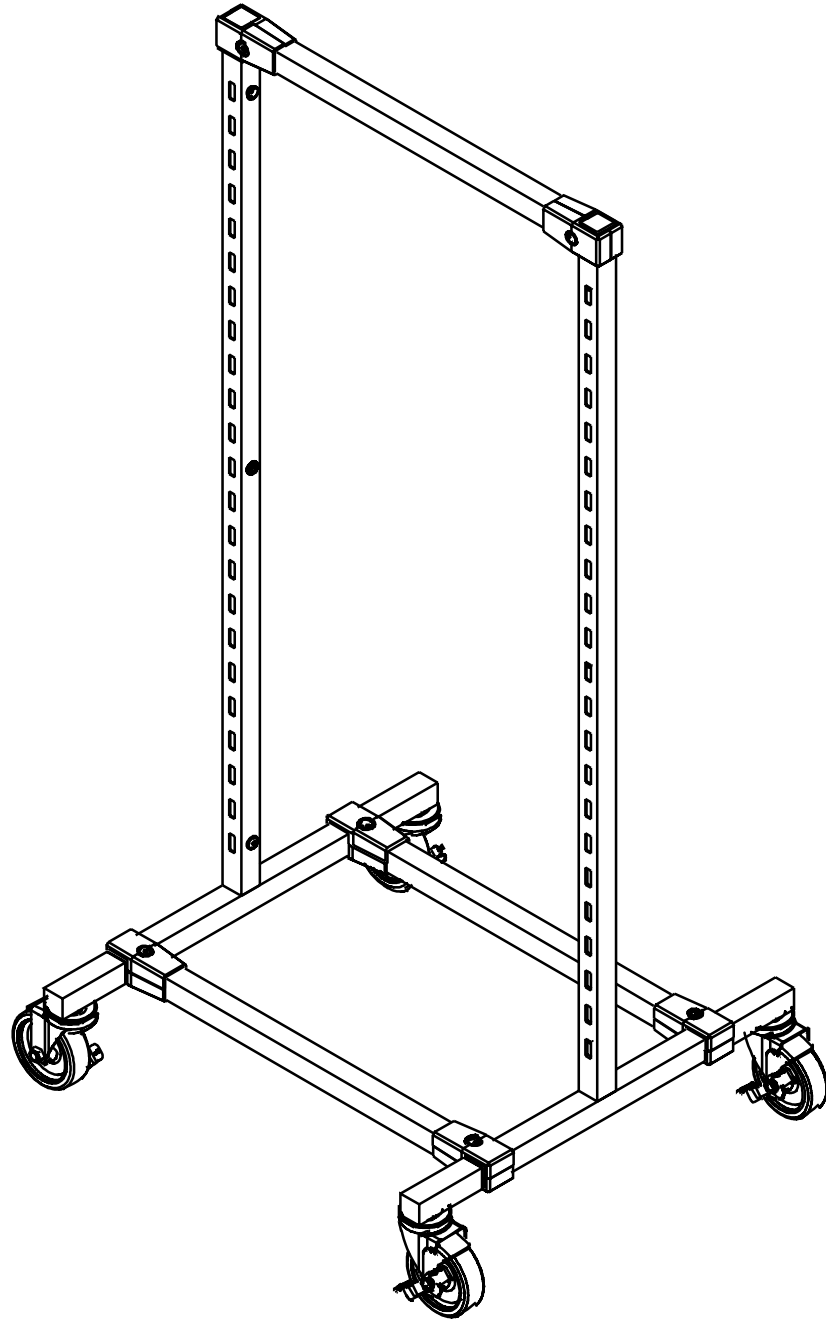

Step 2: Attach top bar

Step 1: Attach bottom bars to build frame.

Step 3: Attach casters

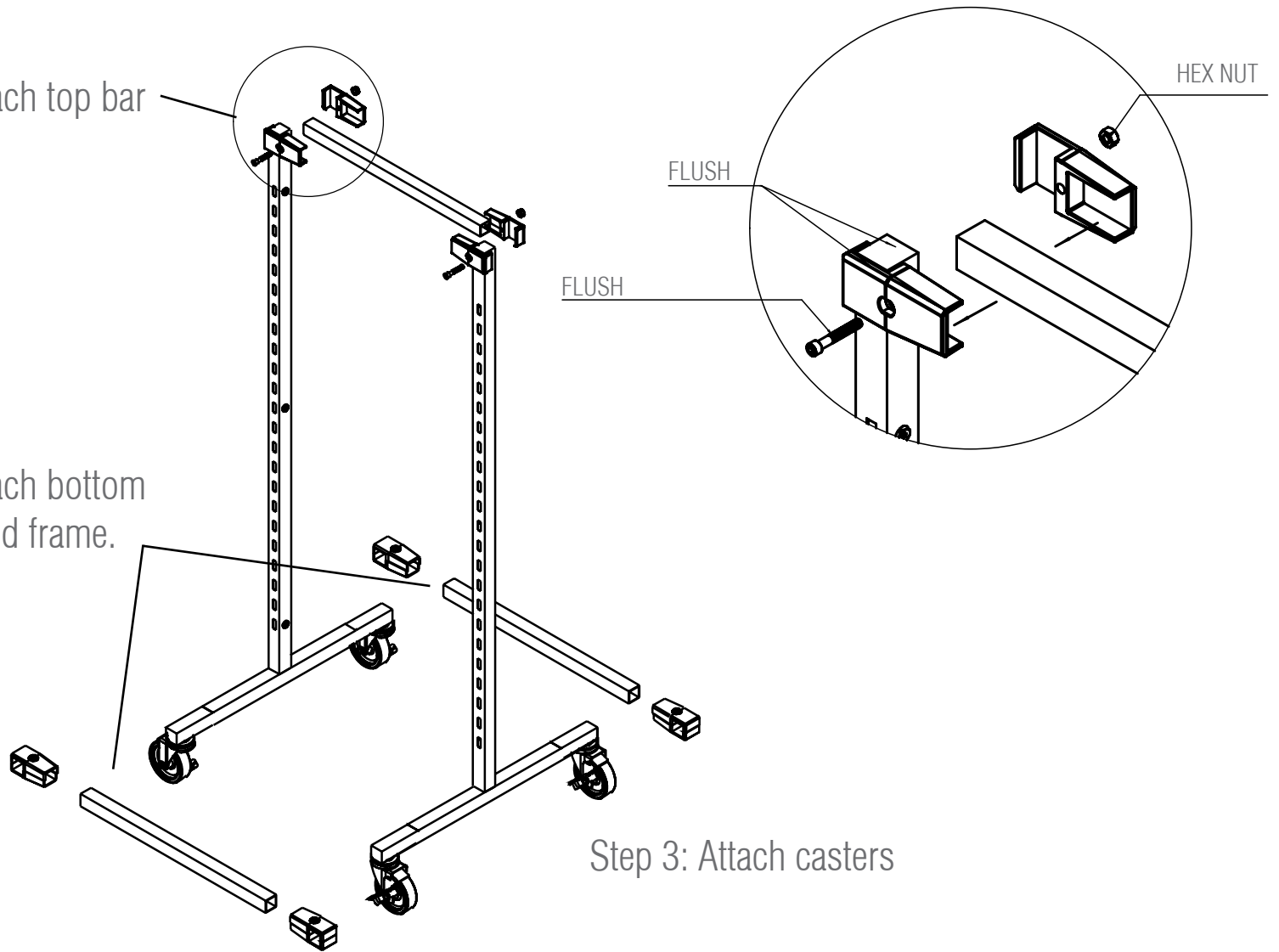

COMPLETE
FIXTURE

